



# ***Installation Guide***

(Revised 02-07-07)



## ***1999 - 2007 Classic Silverado / Sierra***

PRODUCT CODES: "206" & "216"



**ROLL N LOCK CORPORATION**  
915 South Dixie Highway E • Pompano Beach, FL 33060  
**800-952-7655 • [www.rollnlock.com](http://www.rollnlock.com)**

# Installation Guide

## Tools Needed:

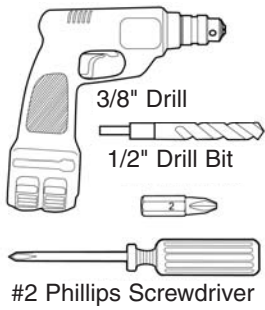

## Components Included:

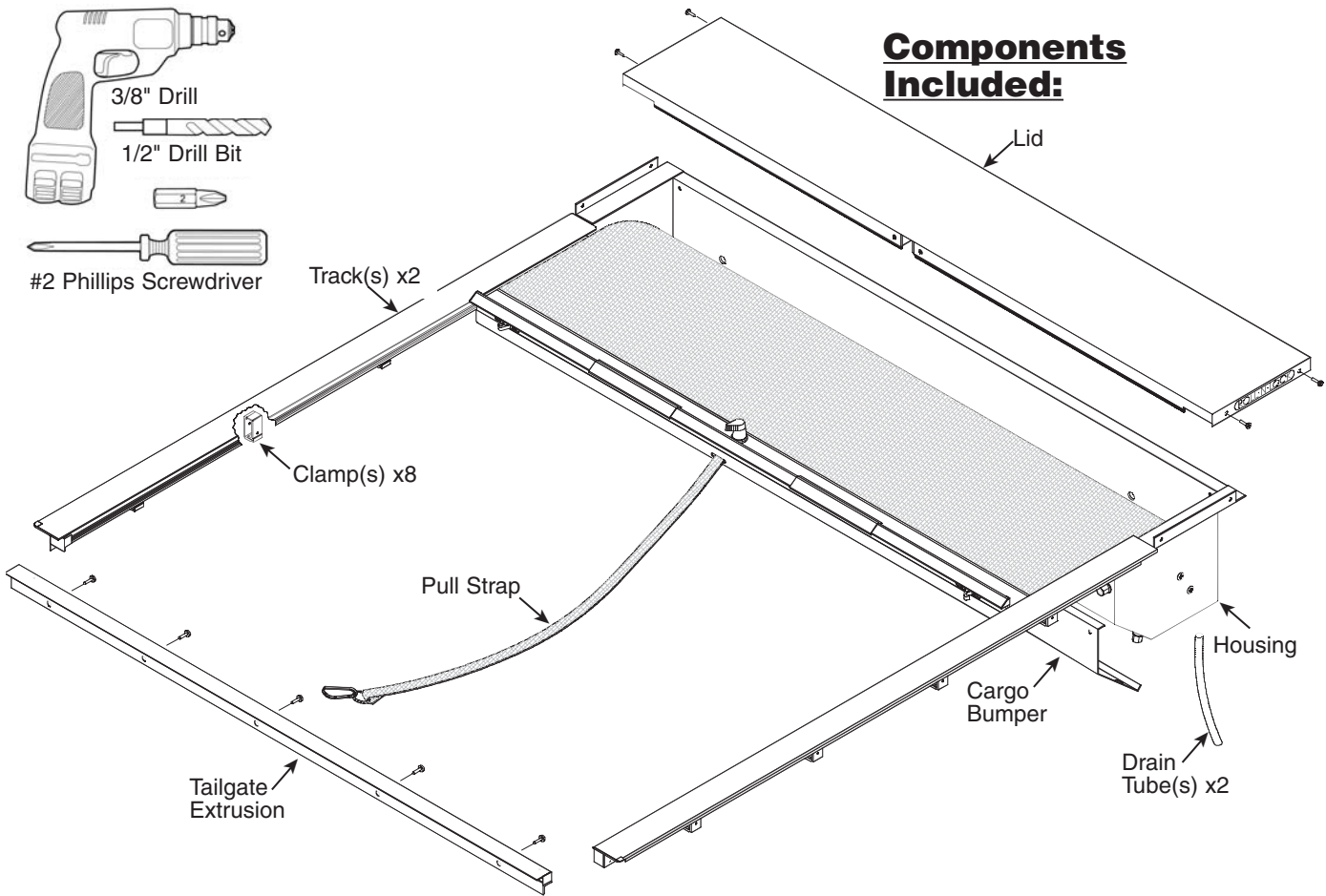

## Step 1: Bedliner Modification

# STOP!

If you have a plastic drop-in bedliner, be sure to follow Step 1 on the next page.

If no bedliner is present, proceed to Step 2.



## Step 1: Bedliner Modification (*Requires Removal from Truck*)

**Note:** If the truck is equipped with a plastic drop-in bedliner, some alteration will be necessary.

**If no bedliner is present, proceed to Step 2.**

**A.** The dotted lines in *Diagram 1* depict the more common **under-the-rail** liner modifications.

1. Using a jig saw with a medium tooth blade, remove the bulkhead portion of the liner as indicated.
2. **Be sure to trim the bedliner's plastic tailgate panel as shown.**

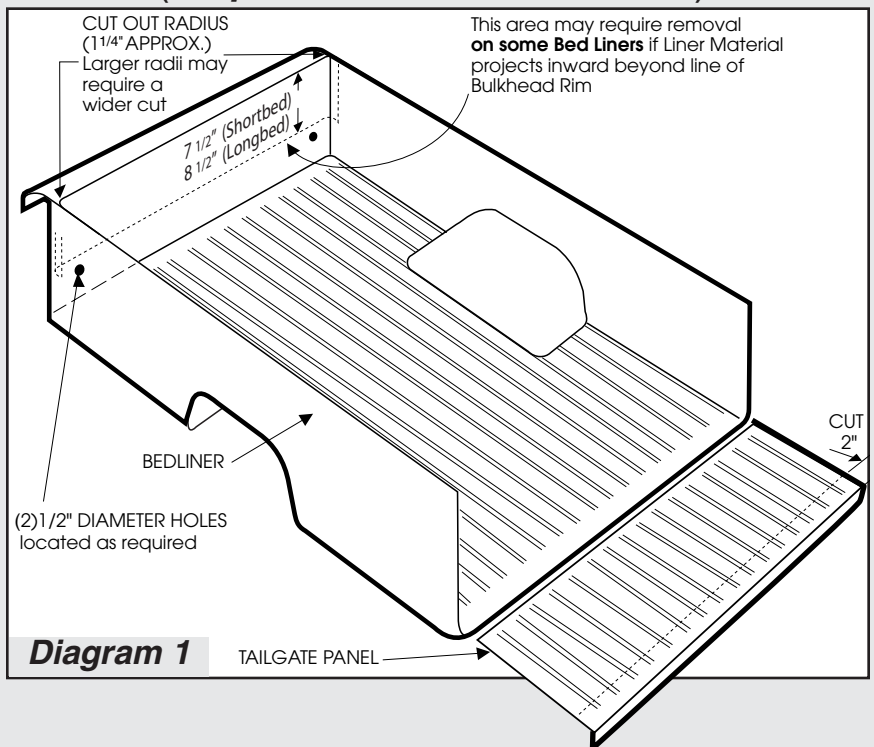

**B.** The dotted lines in *Diagram 2* depict the less common **over-the-rail** liner modifications.

1. Using a jig saw with a medium tooth blade, remove the top cap and cut a "notch" and a "slice" (if necessary) in each side of the bedliner.
2. To locate the notches, place the tracks on their respective bedrails and mark the positions of the most rearward clamps prior to removing the liner. *(The correct position of the track is with the black plastic track end-cap touching the inside surface of the tailgate.)*

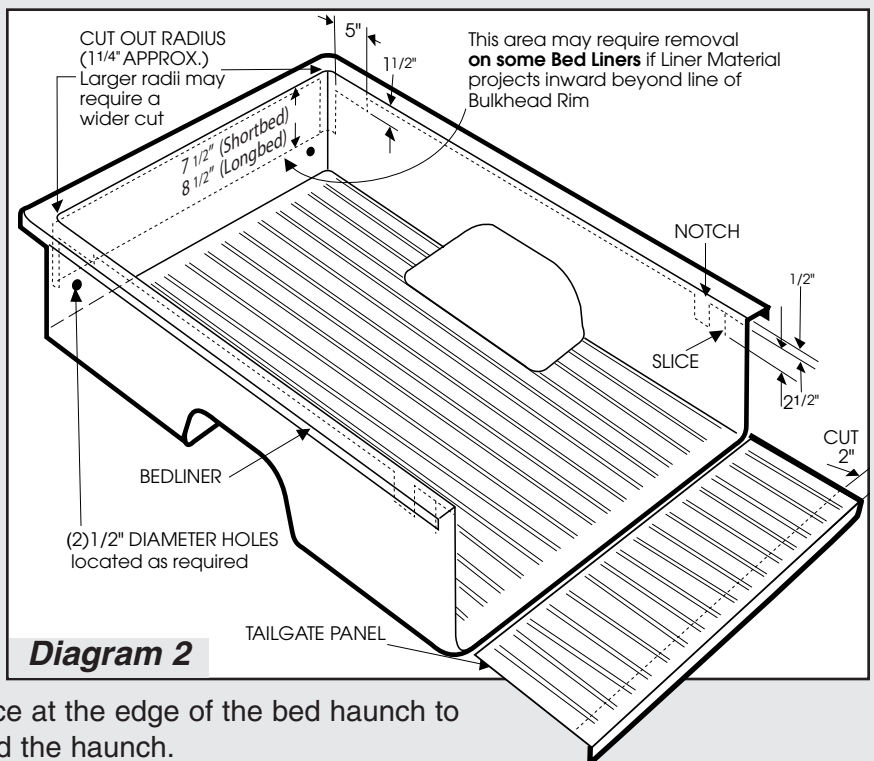

3. If necessary, cut a 2-1/2" slice at the edge of the bed haunch to allow the liner to form around the haunch.
4. When the modification is complete, push the wall of the liner under the bedrail.
5. **Be sure to trim the bedliner's plastic tailgate panel as shown.**

## Step 2: Install the Housing

- A.** If desired, install the stake-pocket hole covers where necessary (*Photo 3*).
- B.** Place the housing assembly onto the bedrails (*Photo 4*). Center it between the bedrails and leave about ½" of space between the bulkhead and the back of the housing. **Do not fasten the housing in place.**

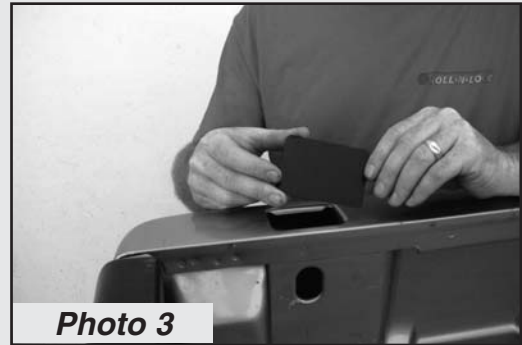

- C.** Remove the lid from the housing and discard the packing bolts (*Photo 5*).

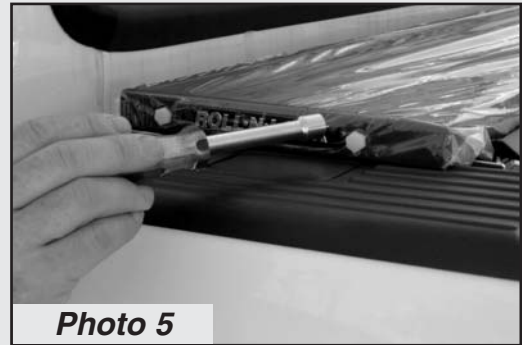

## Step 3: Install the Tracks

- A.** **Making sure to leave the pull-strap connected to the threaded shipping stud,** rotate the latch to the ten o'clock position (*Photo 6*).
- B.** Remove the "L"-shaped sections of clamps that are taped to the bottoms of the tracks (*Photo 7*). **Because these are location-specific, be sure to lay them in the bed in the same order as you remove them from the tracks.**



### **Step 3: Install the Tracks (continued)**

- C.** Carefully place the tracks on the bedrails (*Photo 8*) and key them onto the housing stems, being sure that the handle is properly engaged into the tracks (*Diagram 9*).
- D.** Attach the back clamps very loosely to the tracks to be sure that the tracks do not fall off of the bed rail while proceeding (*Photo 10*).
- E.** Use #10-24 x ½" truss head screws and cargo nuts to secure the tracks to the housing stems (*Photo 11*).
- F.** Attach the remaining clamps very loosely.  
**Do not tighten yet.**



**Photo 8**

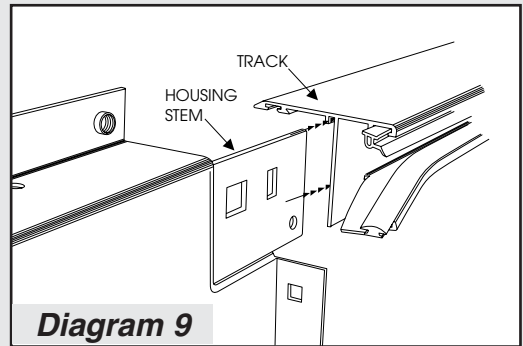

**Diagram 9**



**Photo 10**

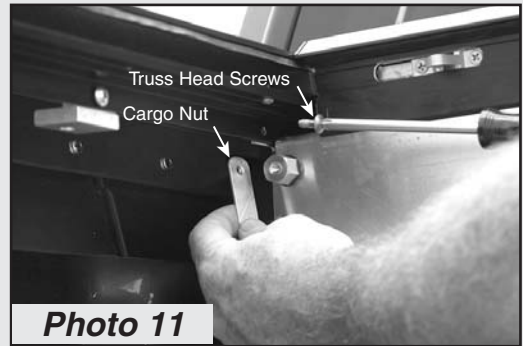

**Photo 11**

### **Step 4: Install the Tailgate Extrusion**

- A.** Lower the tailgate and, using a tape measure, locate and mark the center of the tailgate (*Photo 12*).
- B.** Using a tape measure, locate and mark the center of the tailgate extrusion (*Photo 12*).

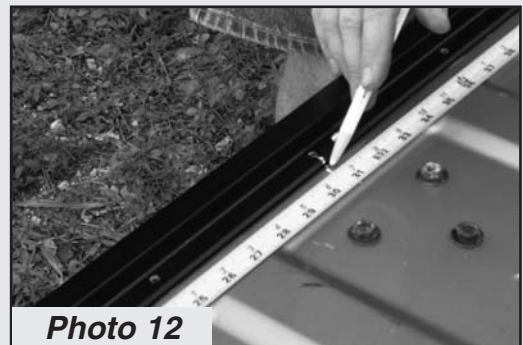

**Photo 12**

## Step 4: Install the Tailgate Extrusion (continued)

**C.** While holding it square and centering the tailgate extrusion on the tailgate, use a #8 x 3/4" self tapping screw and power screw gun to secure the center hole (*Photo 13*). Next, move to each end, **press the tailgate extrusion to the top of the tailgate in order to make it conform to the contour of the tailgate, and secure it in place.**



**D.** Install the remaining self-tapping screws, making sure to provide even spacing between them.

**E.** With the tailgate extrusion secured, carefully close the tailgate, being cautious not to strike the ends of the tracks.

## Step 5: Orienting the Tracks to the Tailgate

**A.** Move to the front of the bed, lift up slightly on the housing and shift each side back toward the tailgate (*Photo 14*) so that the track end-caps contact the inside surface of the tailgate, and match-up with the tailgate extrusion end-caps (*Photo 15*). **Note that if the tracks are not positioned as shown, the lock mechanism will not function correctly.**



**B.** With the tracks in the correct position, you may now tighten the clamps in the order shown (*Diagram 16*), taking care to make sure the tracks remain level. **Do not use a power or pneumatic screw gun. Over tightening track clamps can cause an indentation in the bedrails.**



**C.** If the track rolls upward, rotate the track level and install the optional Angularity Adjustment Screw as shown (*Diagram 17*). Tighten the Screw until it biases against the bedrail down-flange as shown.

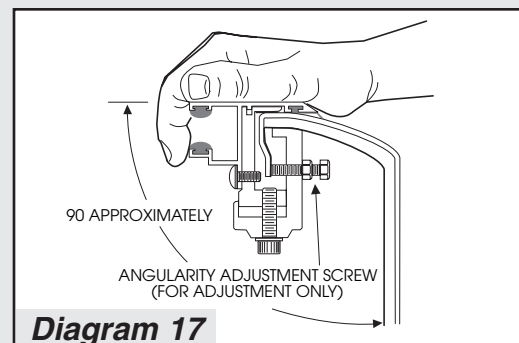
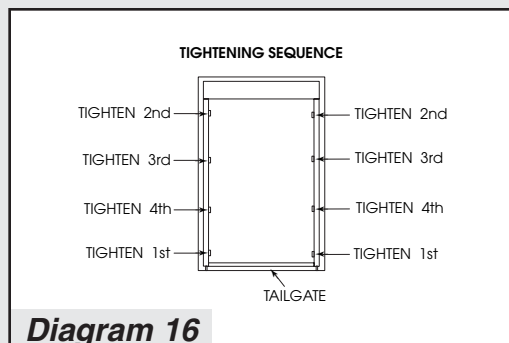

## Step 6: Installing the Lid, Cargo Bumper and Drain Tubes

- A.** Remove the plastic wing nut and detach the pull strap from the threaded stud (*Photo 18*). Pull the cover closed and latch it to the tailgate. **Do not allow the cover to retract without the lid in place.**
- B.** Place the lid onto the housing flanges (*Photo 19*), and secure it in place with  $\frac{1}{4}$  - 20 x  $\frac{5}{8}$ " black countersunk screws. **Do not use a power or pneumatic screw gun.**
- C.** With the lid secured in place, you may test operate the **ROLL-N-LOCK**<sup>®</sup> cover. The cover should retract on its own with only a slight push from the tailgate end. When pulled closed, it should latch effortlessly.
- D.** Use  $\frac{1}{4}$  - 20 x  $\frac{1}{2}$ " truss head screws and rubber washers to secure the cargo bumper (*Photo 20*). **Note that the rubber washers go on the inside of the cargo bumper** (*Diagram 21*).
- E.** Use a  $\frac{1}{2}$ " bit to drill holes for the drain tubes. Note that this process is easier if a  $\frac{1}{4}$ " pilot hole is drilled first. Align the holes with the drain tube fittings and locate them about 3" – 4" below the housing. (*Photo 22*)
- F.** Make sure the pull-strap is securely clipped to a fixed point in the bed.

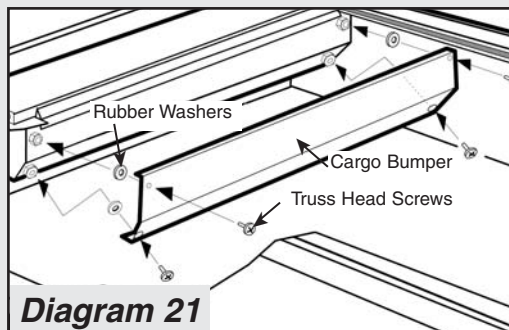

## **Step 7: Place the Hang Tag on Review Mirror**

**A.** Eliminate come-backs by giving your customers a friendly reminder of how to use and maintain their new **ROLL-N-LOCK®** retractable cover for maximum satisfaction. This hang-tag will get noticed immediately on the rear view mirror of your customer's pickup, providing them with everything they need to know. And, they will also appreciate knowing about our new **CARGO MANAGER®**; the perfect accessory for use with **ROLL-N-LOCK®** retractable covers.



# **HOLD ANY SIZE CARGO SECURELY WITH...**

## **CARGO / MANAGER®**

**CARGO MANAGER®**, an optional product for **ROLL-N-LOCK®**, is a movable bed divider that can be positioned at any point along the length of the truck bed to manage and contain lightweight cargo.

- **Easy Positioning**
- **Adjustable Tie-Offs**
- **Flip-Up Feature**
- **Easily Removable**

Weighing only 11 pounds, the **CARGO MANAGER®** can be easily removed when the entire bed space is required.

***See your ROLL-N-LOCK® dealer today!***

G200-1



**ROLL N LOCK CORPORATION**  
915 South Dixie Highway E • Pompano Beach, FL 33060  
**800-952-7655 • www.rollnlock.com**