

# TYPHOON<sup>®</sup> INTAKE SYSTEMS

BY 

## INSTALLATION INSTRUCTIONS

69-1016-1  
HONDA  
2007 Fit  
L4-1.5L

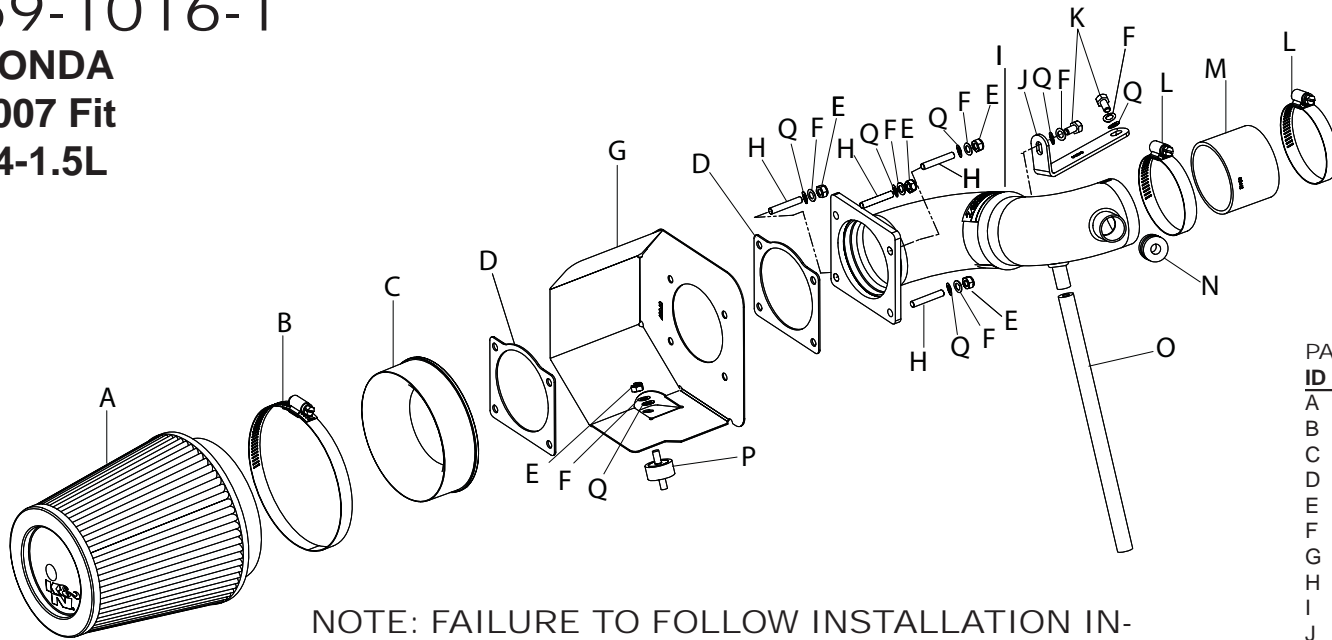

TOOLS NEEDED:  
Ratchet  
Extension 14"  
10mm Socket  
Flat Head Screwdriver  
Phillips Head Screwdriver  
Pliers  
Socket 5.5mm  
Socket 8mm

NOTE: FAILURE TO FOLLOW INSTALLATION INSTRUCTIONS AND NOT USING THE PROVIDED HARDWARE MAY DAMAGE THE INTAKE TUBE, THROTTLE BODY AND ENGINE.

### PARTS LIST

| ID | DESCRIPTION             | QTY | PART NO. |
|----|-------------------------|-----|----------|
| A  | Air filter              | 1   | RU-5163  |
| B  | Hose Clamp #80          | 1   | 08694    |
| C  | Adaptor #350            | 1   | 21510    |
| D  | Gasket                  | 2   | 09202    |
| E  | Nut; 6mm Nylock, SS     | 5   | 07512    |
| F  | Washer                  | 7   | 08277    |
| G  | Heat Shield             | 1   | 07649    |
| H  | Stud; 6mm, SS           | 4   | 08220    |
| I  | Intake Tube             | 1   | 27519    |
| J  | Bracket; "L"            | 1   | 010045   |
| K  | Bolt; 6mm X 12mm L, SS  | 2   | 07727    |
| L  | Hose Clamp #40, SS      | 2   | 08554    |
| M  | Silicone Hose           | 1   | 08441    |
| N  | Grommet                 | 1   | 08100    |
| O  | Hose; 1/4"ID X 17-1/2"L | 1   | 08404    |
| P  | Vibration Mount         | 1   | 07027    |
| Q  | Washer; 6mm flat        | 7   | 08269    |

### TO START:

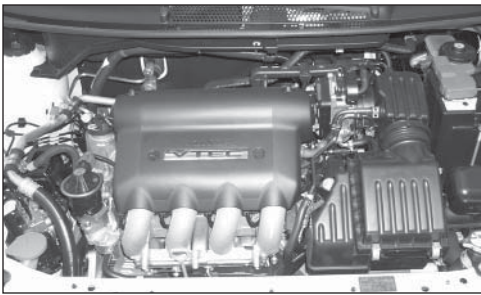

1. Turn the ignition OFF and disconnect the vehicle's negative battery cable.

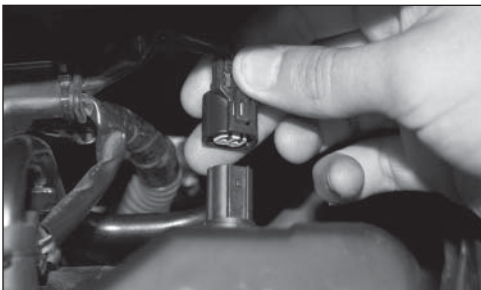

2. Unplug the air temperature sensor from the harness clip.

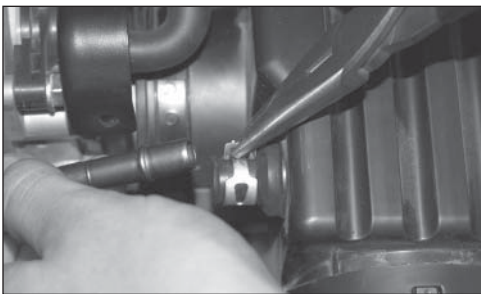

3. With pliers, depress the hose clamp and remove the Crankcase Vent (CCV) hose.

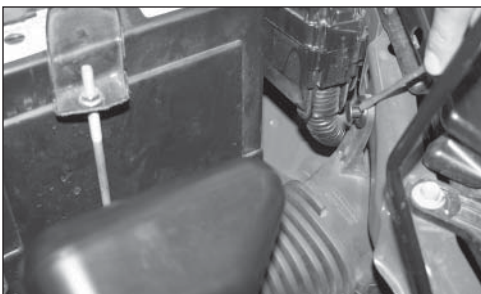

4. Unclip the fresh air duct.

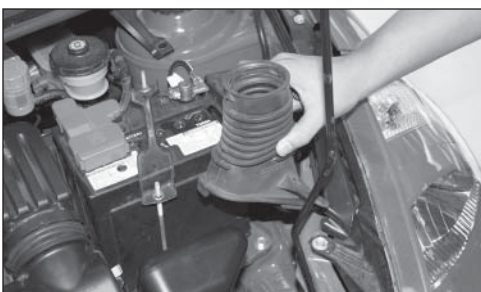

5. Separate the fresh air duct from the factory intake and completely remove.

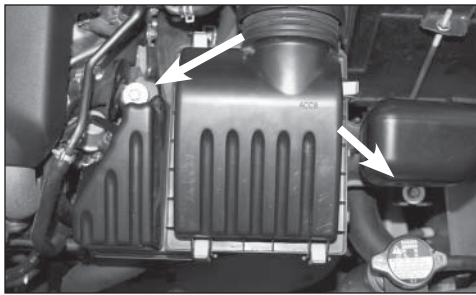

6. Loosen and remove the 2 bolts that secure the factory air box to the vehicle.

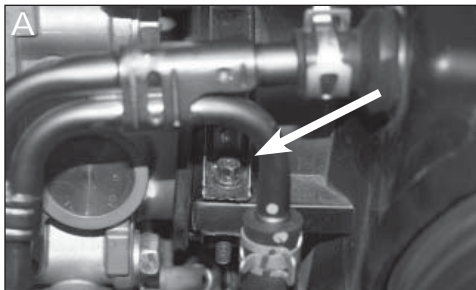

7. Loosen the hose clamp at the throttle body.

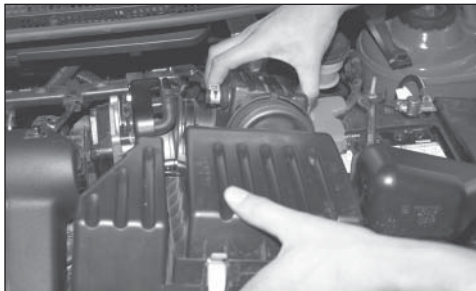

8. Remove the factory air box by pulling away from the throttle body and lifting upwards.

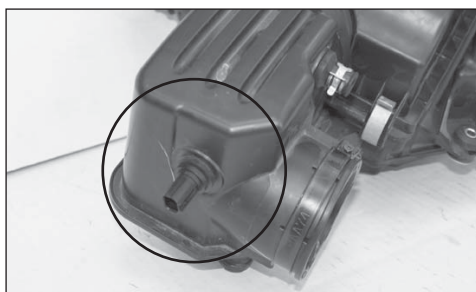

9. Remove the air temperature sensor from the factory air box.

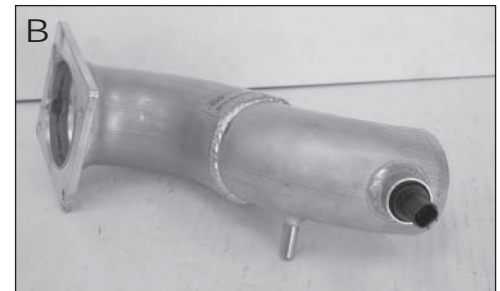
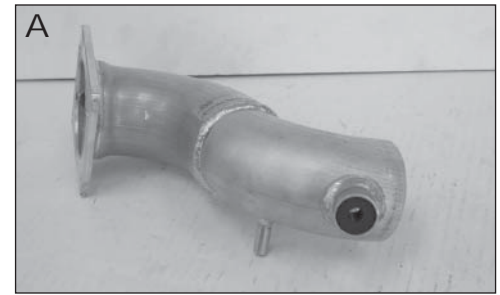

10. Push the provided grommet into the air temp sensor vent tube on the K&N intake tube. Then install the air temp sensor into the grommet.

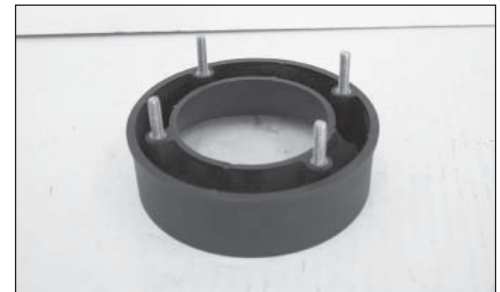

11. Install the provided threaded studs into the filter adaptor.

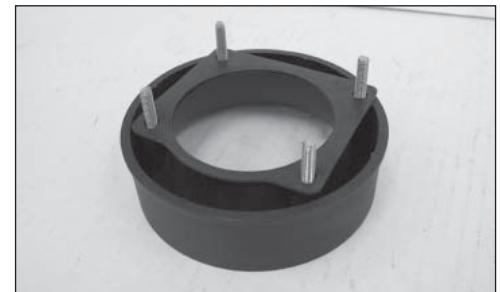

12. Install the gasket onto the filter adaptor as shown.



13. Attach the K&N air filter to the adaptor assembly, and tighten the hose clamp.

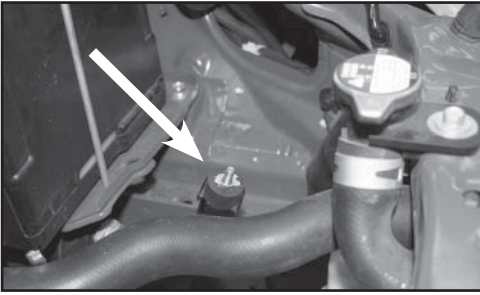

14. Install the provided rubber mounted stud into the threaded hole where the factory air box was mounted.

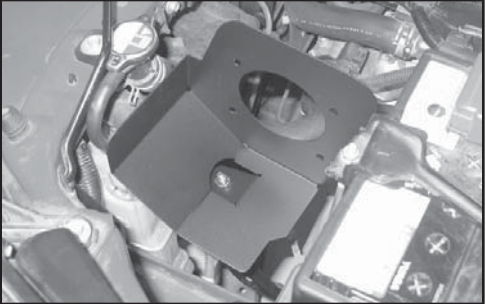

15. Place the heat shield onto the rubber mounted stud, then place the provided hardware. Pivot the heat shield around.

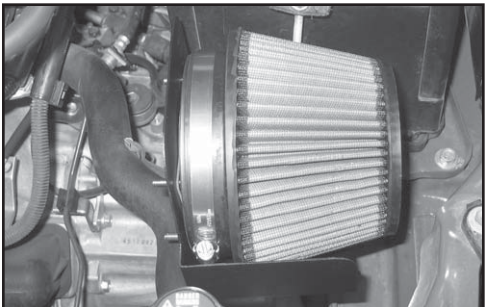

16. Place the filter assembly on the heat shield as shown. Tighten the lock nut on the vibration mount.

**NOTE: Heat shield should be perpendicular (90 degrees) to the battery. It may be necessary to loosen the battery and move it back to gain clearance for the heat shield**

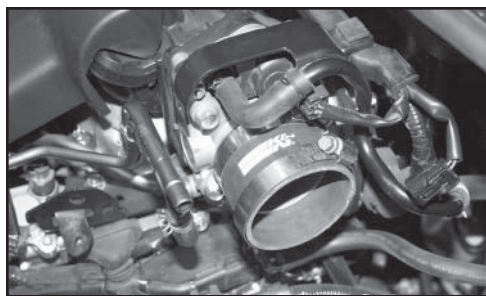

17. Attach the silicone hose to the throttle body with the hose clamps provided.

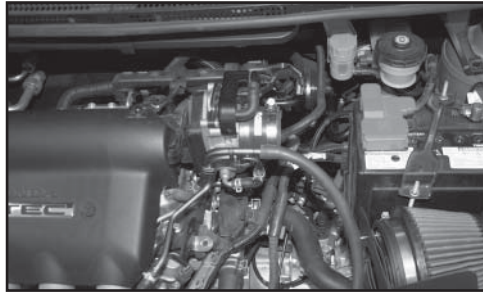

18. Attach the silicone hose to the crankcase vent hose on the engine valve cover as shown.

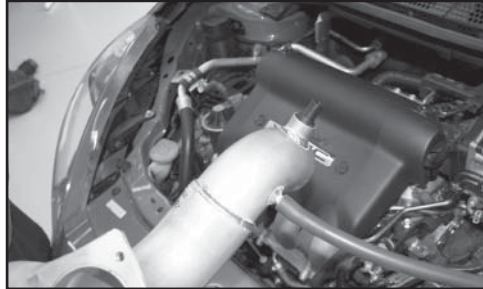

19. Install the other end of the silicone hose to the vent line on the K&N intake tube.



20. Place the gasket on the heat shield, as shown.

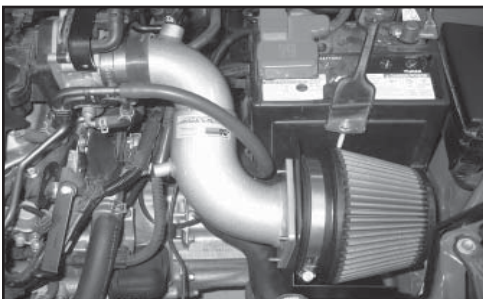

21. Install the K&N intake tube on the heat shield first, then to the hose on the throttle body.

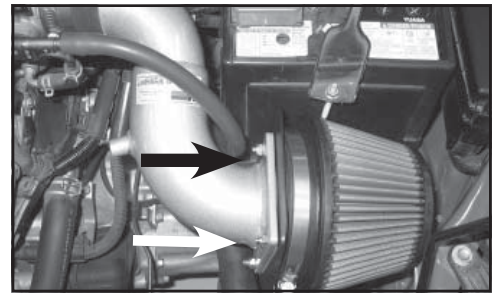

22. Secure the K&N intake tube to the heat shield using the provided hardware.

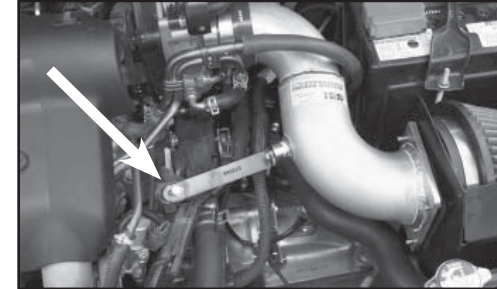

23. Install the "L" bracket and secure with the provided hardware.

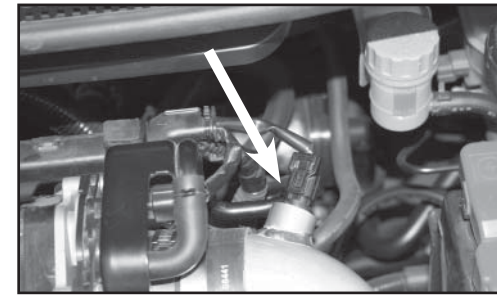

24. Clip the ATS harness into the air temperature sensor.

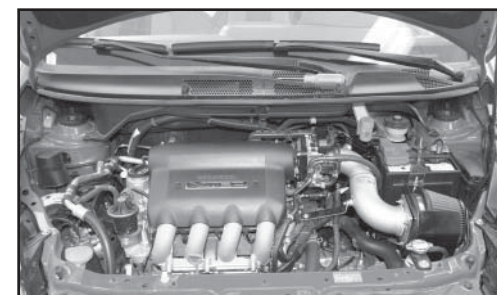

25. Check for best fit, then tighten all hardware and hose clamps.

26. Reconnect the negative battery cable and double check to make sure everything is tightened and properly positioned before starting the vehicle.

27. It will be necessary for all Typhoons to be checked periodically for realignment, clearance and tightening of all connections. Failure to follow the above instructions or proper maintenance may void warranty.

#### ROAD TESTING

1. Start the engine with the transmission in neutral or park, and the parking brake engaged. Listen for air leaks or odd noises. For air leaks secure hoses and connections. For odd noises, find cause and repair before proceeding. This kit will function identically to the factory system except for being louder and much more responsive.

2. Test drive the vehicle. Listen for odd noises or rattles and fix as necessary.

3. If road test is fine, you can now enjoy the added power and performance from your kit.

4. K&N suggests checking the Air Filter element periodically for excessive dirt build-up. When the element becomes covered in dirt (or once a year), service it according to the instructions on the Recharger service kit, part number 99-5000 or 99-5050.

**\*FREE K&N DECAL To register your warranty, please see us online at [knfilters.com/register](http://knfilters.com/register). FREE K&N DECAL\***