

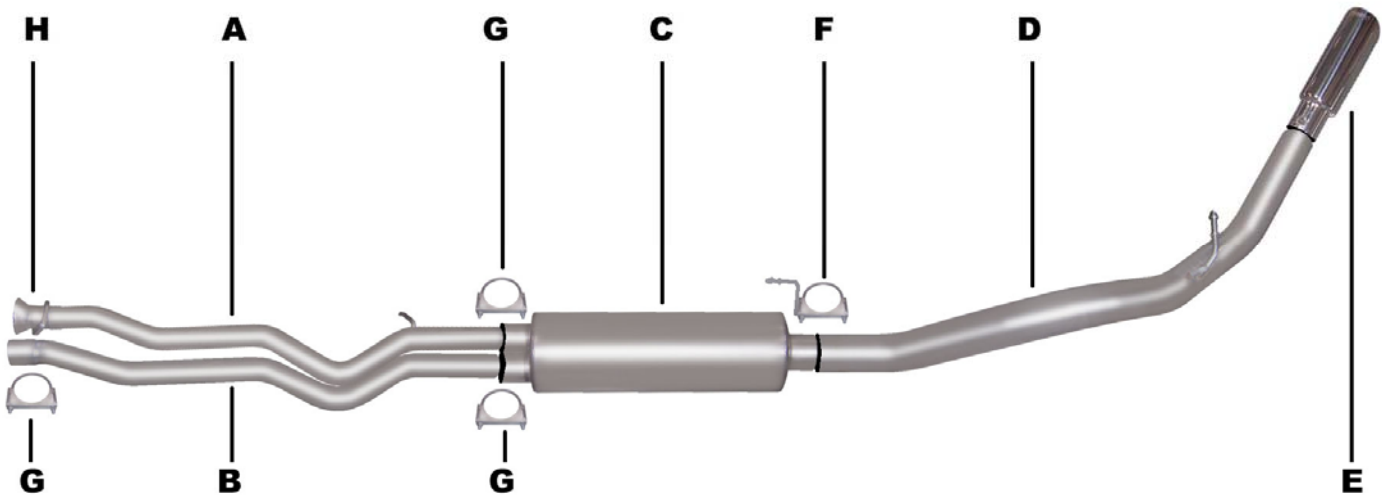

**INSTALLATION INSTRUCTIONS**  
**CAT BACK STAINLESS SINGLE EXHAUST**  
**2006 CHEVY SILVERADO 1500 SS VORTEC MAX 6.0L 2/4WD**  
**EXTENDED & CREW CAB, STANDARD BED**  
**PART #615596**



ITEM	PART #	QUANTITY	DESCRIPTION
A	650-700512S	1	2½" Stainless Passenger side headpipe w/GP-305 flange
B	1085-700825S	1	2½" Stainless Driver side headpipe
C	758250S	1	Stainless Superflow muffler
D	1099-700826S	1	3" Stainless Overaxle tailpipe w/hanger
E	500379	1	4" Stainless tip
F	4224	1	Rear muffler hanger
G	5757	3	2½" Clamp
H	BO-1018	1	Bolt kit for headpipe

Thank you for purchasing our Gibson exhaust system for your vehicle. If you need further assistance, please do not hesitate to call our technical dept at (800) 528-3044 Monday through Friday, 8:00 am to 5:00 pm. 0806

# INSTALLATION INSTRUCTIONS #615596

## CAREFULLY READ INSTRUCTIONS BEFORE STARTING INSTALLATION.

When installing this exhaust system make sure to use proper safety precautions. Use jack stands when working under the vehicle, set parking brake, block tires and use safety glasses and gloves. Allow exhaust to cool before attempting installation. Severe injury or burns could occur if safety measures are not taken.

**SUGGESTED TOOLS:** 1/2", 9/16" 15mm wrenches & sockets, WD-40, hacksaw, jack stands.

.....  
: Disconnect the negative battery cable before removal of OEM exhaust. This will allow the computer to reset and recognize the  
: new exhaust. Lay out the exhaust on the floor so it looks like the drawing and compare parts with manual.  
: .....



**1.** To remove the stock exhaust un-bolt it from factory Y-pipe. Disengage the welded hangers using WD-40 from the OEM rubber grommets. Do not damage or remove the rubber grommets as you will re-use them to mount your new system. Now, cut off tailpipe just behind the muffler and remove exhaust.

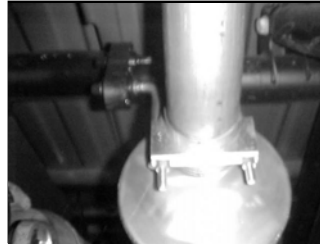

**4.** Install rear muffler hanger #F onto muffler, insert into rubber grommet. Insert over axle pipe into muffler 1½"-2". DO NOT TIGHTEN.



**2.** Install passenger head pipe #A onto stock Y-pipe with bolt kit #H. Use a jack stand to support the headpipe. DO NOT TIGHTEN. Insert welded hanger into rubber grommet. Next install driver headpipe #B onto the factory pipe, secure with clamp #G. DO NOT TIGHTEN.



**5.** Next, insert the welded hanger from over axle pipe into rubber grommet. Rotate pipe for proper angle and clearance.



**3.** Install muffler #C onto headpipes 1½"-2" with the louvers facing towards the Y-pipe. Use a jack stand to support the muffler. Use clamp #G to secure the muffler to the headpipes. DO NOT TIGHTEN.

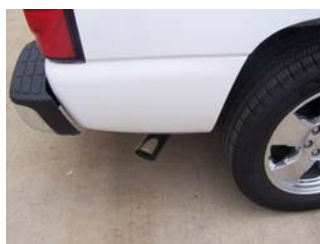

**6.** Install stainless steel tips #E. Clamp down. When you have everything in place, firmly tighten all bolts and clamps down securely. Use stainless steel cleaner and a Scotch Brite pad weekly to prevent tip from discoloration.