



INSTRUCTION MANUAL

CAT-BACK STAINLESS SINGLE EXHAUST

94-95 CHEVY TRUCK 4.3L, 5.0L, 5.7L 4WD

EXTENDED CAB, LONG BED

PART # 615576L

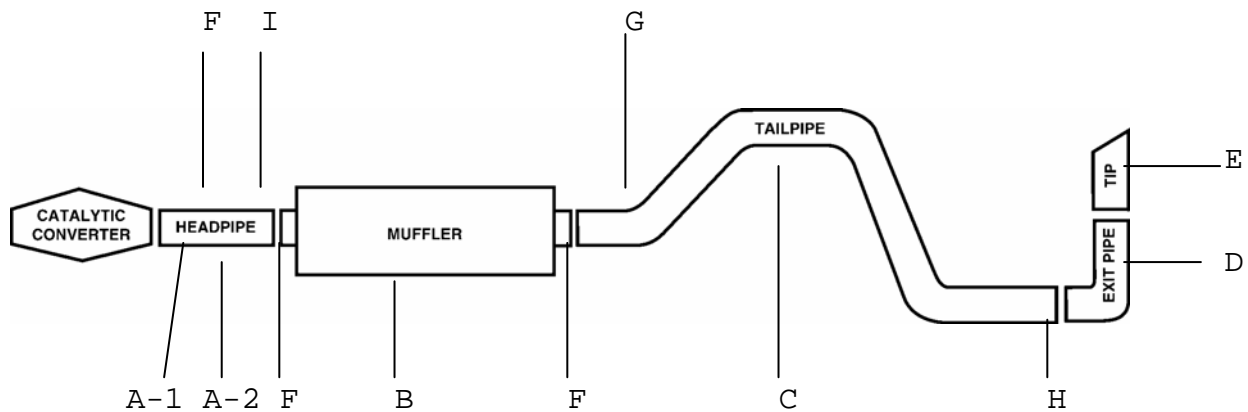

ITEM	PART #	QUANTITY	DESCRIPTION
A-1	286-50036S-1	1	3"X36" STAINLESS HEADPIPE WITH FLANGE#GP-105
A-2	116-30027S	1	3" X 27" STAINLESS HEADPIPE
B	420887	1	3" STAINLESS SUPERFLOW MUFFLER
C	110-50030RS	1	3" OVERAXLE STAINLESS TAILPIPE
D	117-50032RS	1	3" TURNOUT STAINLESS PIPE
E	500360	1	3-1/2" STAINLESS TIP
F	OHD300	3	3" CLAMP
G	500441	1	TAILPIPE HANGER
H	500442	1	TAILPIPE REAR HANGER
I	500448	1	FRONT HEADPIPE HANGER

Thank you for purchasing our GIBSON EXHAUST SYSTEM for your vehicle. If you need further assistance, please do not hesitate to call our Technical Department at (800) 528-3044, Monday through Friday, 8:00 am to 5:00 pm. 0903

EXHAUST INSTALLATION #615576L

WHEN INSTALLING THIS EXHAUST SYSTEM MAKE SURE TO USE THE PROPER SAFETY PRECAUTIONS. USE JACK STANDS WHEN UNDER THE TRUCK, SET PARKING BRAKE, BLOCK TIRES, AND USE SAFETY GLASSES AND GLOVES. DO NOT WORK WITH HOT PIPES!

1. Raise vehicle and support with stands. Unbolt stock flange behind the rear of the converter. Use jack stands to support converter so it won't drop. Remove stock hangers leaving all rubber mounting grommets in place. Cut the stock tailpipe for easy removal.
2. Lay out the GIBSON EXHAUST SYSTEM on the floor so it looks like the drawing.
3. Connect headpipe # A-1 to the stock flange behind the converter re-using your stock bolts and attach with clamp # F. Attach headpipe # A-2, and attach with clamp # F.
4. Connect muffler with inlet towards the converter to the headpipe. Use a jack stand to support the muffler and connect clamp # F. Attach headpipe hanger # I to the headpipe. Muffler inlet is looking into the louvers.
5. Install the overaxle tailpipe # C connect to the muffler and clamp # F. Attach hanger # G to tailpipe.
6. Connect turnout exit pipe # D to the rear of overaxle pipe. Roll turnout pipe until you have it at the correct angle for your truck and connect with clamp # H.
7. Install stainless steel tip. Clamp down. To clean stainless tip use a scott brite pad and any stainless steel or aluminum cleaner.
8. When you have everything in place, firmly tighten all bolts and clamp down securely.

MAKE SURE YOU HAVE A 1" CLEARANCE ON ALL PIPES FROM ALL RUBBER BRAKE LINES, FUEL LINES, SHOCK BOOTS, TIRES, ETC.